

## Specifications

MEASUREMENTS	Metric	US
Working height	8.07 m	25 ft 11 in
Platform height	6.00 m	19 ft 11 in
<b>A</b> <b>B</b> Platform dimensions (l x w)		
Standard	0.89 x 0.75 m	35 x 29.5 in
Standard with extension	1.40 x 0.75 m	55 x 29.5 in
<b>C</b> Height - stowed	1.97	6 ft 6 in
<b>D</b> Length - stowed	1.35	4 ft 5 in
<b>E</b> Width	0.80 m	2 ft 7.5 in
<b>F</b> Ground clearance - centre	0.06 m	2.5 in

PRODUCTIVITY		
Lift capacity	159 kg	350 lbs
Lift capacity - extension deck	113 kg	250 lbs
Drive speed - stowed	4.0 km/h	2.5 mph
Drive speed - raised	0.8 km/h	0.5 mph
Gradeability	30%	30%
Turning radius - inside	zero	zero
- outside	1.42 m	4 ft 7 in
Raise/lower speed	24/21 sec	24/21 sec
Controls	24V DC proportional	
Tyres - solid non-marking	25 x 8 x 20 cm	10 x 3 x 8 in

POWER		
Power source	24 V (four 6 V 225 Ah batteries)	
Hydraulic system capacity	8.33 L	2.2 gal

WEIGHT		
	1112 kg	2,451 lbs

STANDARDS COMPLIANCE	ANSI A92.6, CSA B354.2, CE Compliance, AS 1418.10
----------------------	---

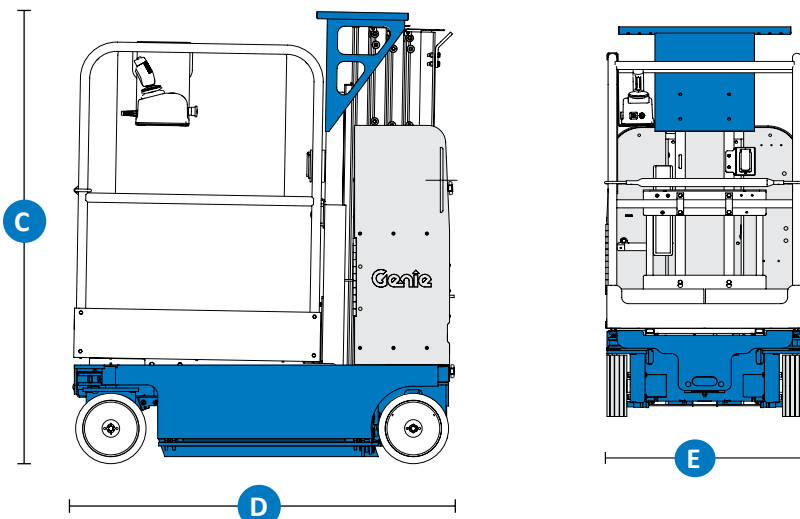
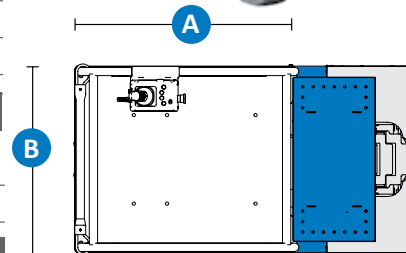

## STANDARD FEATURES

### PRODUCTIVITY

- Extension platform with sliding mid-rail
- Work station tray
- Auxiliary platform lowering
- Low 0.39 m (15.5 in) platform entry height
- Patented rigid mast system
- Fully proportional lift and drive controls
- Battery charge indicator
- Onboard diagnostic system
- Tilt alarm
- Zero inside turning radius
- Dual wheel brakes
- Hydraulic brake release
- Pothole protection
- Hinged rear ABS covers for easy access to all major electrical and hydraulic components
- Tie down attachment points
- Overhead crane attachment point
- Large forklift pockets access
- Non-marking solid tyres
- Dual flashing beacons
- Motion alarm
- Automotive horn
- Descent alarm

### POWER

- Automatic 25 amp battery charger